



## Section 09 50 Ceilings

### Part 1 – General

#### 1.01 Scope

Furnish and install the Exterior Ceiling metal tile ceiling system (Security Snap-In, Exterior Torsion Spring, Patternz or Custom) as manufactured by Steel Ceilings Inc., Johnstown, Ohio.

#### 1.02 Related Sections

- Section 09 20 Plaster and Gypsum Board
- Section 23 00 Heating, Ventilating and Air-conditioning
- Section 26 50 Lighting

#### 1.03 References

- American Society for Testing and Materials (ASTM)

**C635** Standard specification for the manufacture, performance and testing of metal suspension systems for acoustical tile and lay-in panel ceilings

**C636** Standard practice for installation of metal ceiling suspension systems for acoustical tile and lay-in panels

**E84** Test method for surface burning characteristics of building materials

**CISCA** Ceilings and Interior Systems Construction Association

#### 1.04 Submittals

- Provide product data sheets listing dimensions, style, edge detail, perforation pattern and finish
- Alternates require prior approval no later than 21 days prior to bid date. In addition to the requirements above, submittals for approved alternates must include samples of actual products to be substituted together with test certificates supporting performance claims, a mock up and a written warranty.

#### 1.05 Project Conditions

##### Environmental Requirements

- Area to receive ceiling systems shall be protected from the direct weather
- Wet trades work shall be complete and dry prior to installation of ceiling system

#### 1.06 Attic Stock

Provide 2% of the ceiling system area materials to be used as attic stock

#### 1.07 Performance

- Materials and installation must comply with Local Building Code and Regulations
- Materials should be stored and handled in accordance with CISCA's *Acoustical Ceilings – Use and Practice*
- Materials to comply to CISCA's *Metal Ceilings Technical Guidelines*

- System is to comply with wind load requirements. Wind speed is converted into a testing of pounds-per-square-foot, such that the ceiling must withstand 40 lbs upward/positive force and 20 lbs of downward or negative force (or such other standards as set out by the architect or engineer hereunder)
- There are no special seismic requirements

### Part 2 – Products

#### 2.01 Manufacturer

- Concealed Snap T-bar suspension system, clips, molding and metal pans, or
- Exterior Torsion Spring slotted tee-grid, compression camlocks, molding and metal pans, or
- Patternz, or
- Custom shall be as manufactured by Steel Ceilings Inc., Johnstown, Ohio: [www.steelceilings.com](http://www.steelceilings.com)

#### 2.02 Materials

##### 1 Snap-In Suspension System and Panels

- Primary Channel shall be 1½" deep 16-gauge galvanized steel — minimum G60, and shall be spaced not to exceed 24" on center by direct suspension from the existing structure with not less than 16-gauge 1½" x 1½" G60 galvanized angle, spaced 48 inches along the component length. Brace where necessary.
- Snap T-bars shall be galvanized steel — minimum A40/G40 and attached with galvanized wire clips at right angles to the 1½" primary channel. In addition, snap bars shall be screwed to the primary channel once installed.
- Wall molding shall be formed from 18-gauge steel (or 0.063" aluminum) in C-shape to receive metal pans
- Hold downs shall be formed from same materials as the molding
- Metal pans shall be formed from galvanized steel 24-gauge (or aluminum 0.040")
- Panels shall measure 24" x 24"
- Panels shall be bevel edge
- Panels shall be non-perforated (or perforated with...)
- Panels shall be post painted 360° with polyester powder global white (color) gloss level 12% to 15% rated for exterior (or natural anodized)

##### 2 Torsion Spring Suspension System and Panels

- Heavy duty slotted main tees shall be spaced not to exceed 24" on center by direct suspension from the existing structure with not less than 16-gauge 1½" x 1½" G60 angle, spaced 24" along the main tee

- Heavy duty cross tees 24" long should be set at 24" centers along the main tee
- Wall molding shall be formed from 18-gauge galvanized steel (or 0.063" aluminum) in C-shape to receive metal pans
- Hold downs shall be formed from same materials as the molding
- Metal pans shall be formed from 24-gauge galvanized steel (or 0.040" aluminum) up to 24" x 24" (0.050"/0.063" aluminum for larger panels)
- Panels shall measure 24" x 24" (Panels shall be 48" x 48" with compression camlocks and extra-heavy-duty springs)
- Panels shall be square edge
- Panels shall be non-perforated (or perforated with...)
- Panels shall be post painted 360° with polyester powder global white (color) gloss level 12% to 15% rated for exterior (or natural anodized)

#### 3 Patternz

- Patternz wire panels to be supplied in galvanized steel, aluminum or stainless steel
- Overall sizes and cell size to be as shown on drawing
- Hold down clips shall secure panels at a minimum of four places.

#### 4 Custom

### Part 3 – Execution

#### 3.01 Examination

- Installer must inspect the area that is to receive the metal ceiling system for conditions that may affect the installation and notify, in writing, any conditions that must be rectified before commencing
- All work above the ceiling shall be completed before proceeding with this installation
- All wet work shall be completed and thoroughly dry before proceeding with this installation

#### 3.02 Installation

- Metal Ceiling components shall be delivered in unopened cartons and shall be clearly marked with manufacturer's name
- Material shall be stored in dry and protected areas
- Install the ceiling system in accordance with the manufacturer's recommendations and the approved shop drawings
- Cut panels shall, where possible, not be less than one half of full size
- Panels shall be free from defects and damaged panels shall be removed and replaced

# EXTERIOR CEILING METAL PAN SYSTEM

SIZE (INCHES)	Min. 12x24, Max. 36x96
ACCESSIBILITY	Exit panel only
VISUAL	Concealed
EDGE DETAIL	Square
MATERIALS	Steel, Aluminum, Stainless
FINISHES	Painted, Natural
RELATIVE COST	\$\$

**EXTERIOR TORSION SPRING WITH CAM LOCK**  
(REFER TO TORSION SPRING, PAGE 2A)

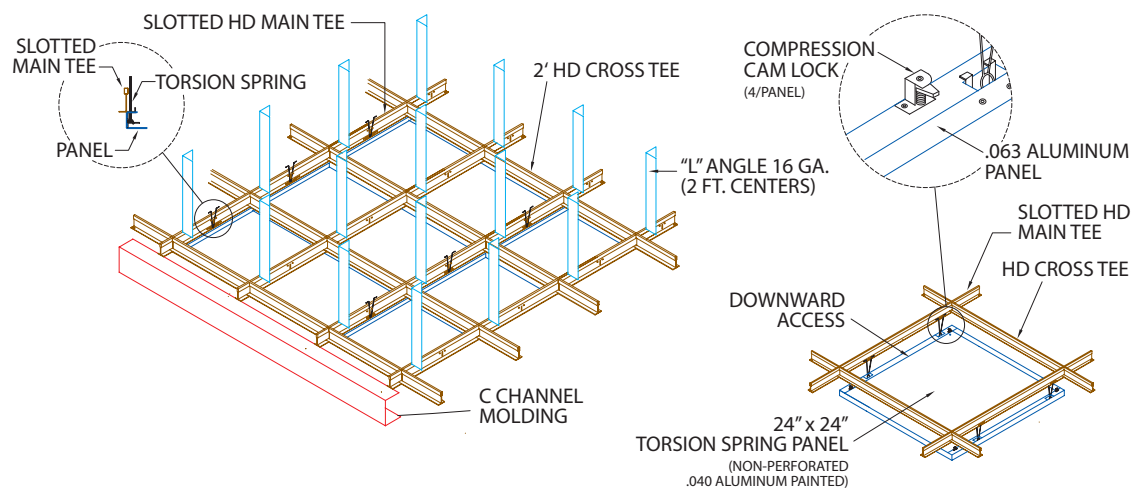

**STANDARD EXTERIOR SNAP-IN**  
(REFER TO SNAP-IN, PAGE 2I)

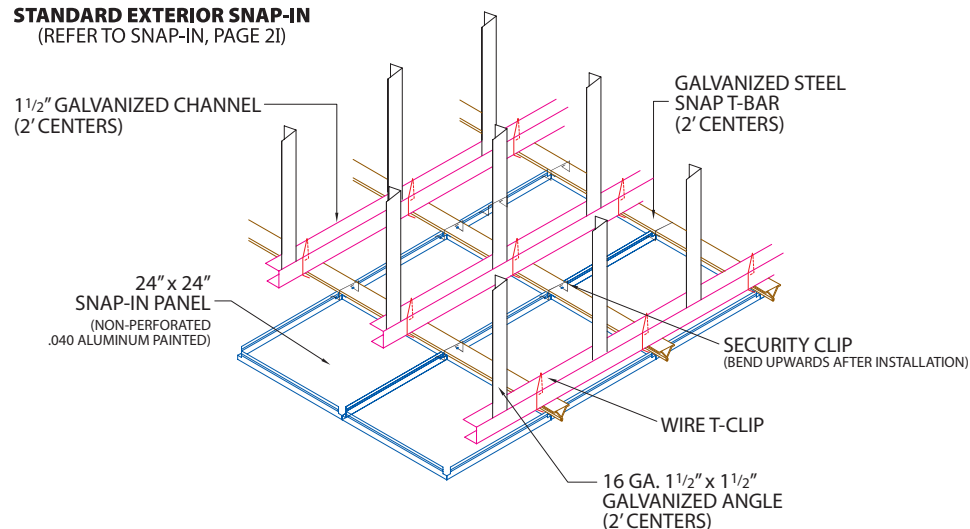

**OVERVIEW**

Steel Ceilings Exterior Ceiling Systems include those that are outside the building but under a soffit or overhang, so that they are not directly exposed to the weather. Exterior ceiling systems are based on Security Snap-In, Torsion Spring, Patternz, Plank or Custom.

**MODULE**

Modules vary; typically 24" x 24", 24" x 48" and 48" x 48", with a maximum up to 12" x 120"

**METAL**

The type of metal recommended depends primarily on the geographic location of the project. In dry climates galvanized steel is adequate, whereas in more corrosive areas, aluminum or stainless steel (normally #304) is required. In highly corrosive areas, stainless steel #316 may be more appropriate. The thickness of the material is normally dictated by the panel size.

**PERFORATIONS**

If the external panel is to have perforation holes, consideration should be given to the effect of wind and air pressure on any unprotected acoustic fiberglass pads behind the holes. For larger aesthetic holes, Steel Ceilings can include a screen behind the holes to minimize egress by birds or rodents.

**WIND LOAD**

One of the most important aspects of an external ceiling under a soffit is wind load. Wind loads are measured in miles per hour, but product is tested by converting this to pressure in pounds-per-square-foot — either positive (upward) or negative (downward). With positive pressure, the substructure behind the ceiling panels is most important. Main tees or black iron are usually spaced at 2-foot centers. Wind load test certificates for 2 ft. x 2 ft. Snap-In, 2 ft. x 2 ft. and 4 ft. x 4 ft. Torsion Spring are available on request. Wind load does not have an impact on Patternz wire ceilings.

**FINISHES**

Finishes can include paint (360°), anodized or brushed (for stainless steel). Steel Ceilings Patternz should be galvanized.

**APPLICATIONS**

Steel Ceilings should be advised of the local regulations and laws with which the ceiling may need to comply.